

بازرگانی رحیمی

جرثقیل . وینچ

تجهيزات جابجایی کالا



تلفن: 55423151 و 55423152

فکس: 55423150

Email: ITSCO@neda.net.ir

بازرگانی رحیمی

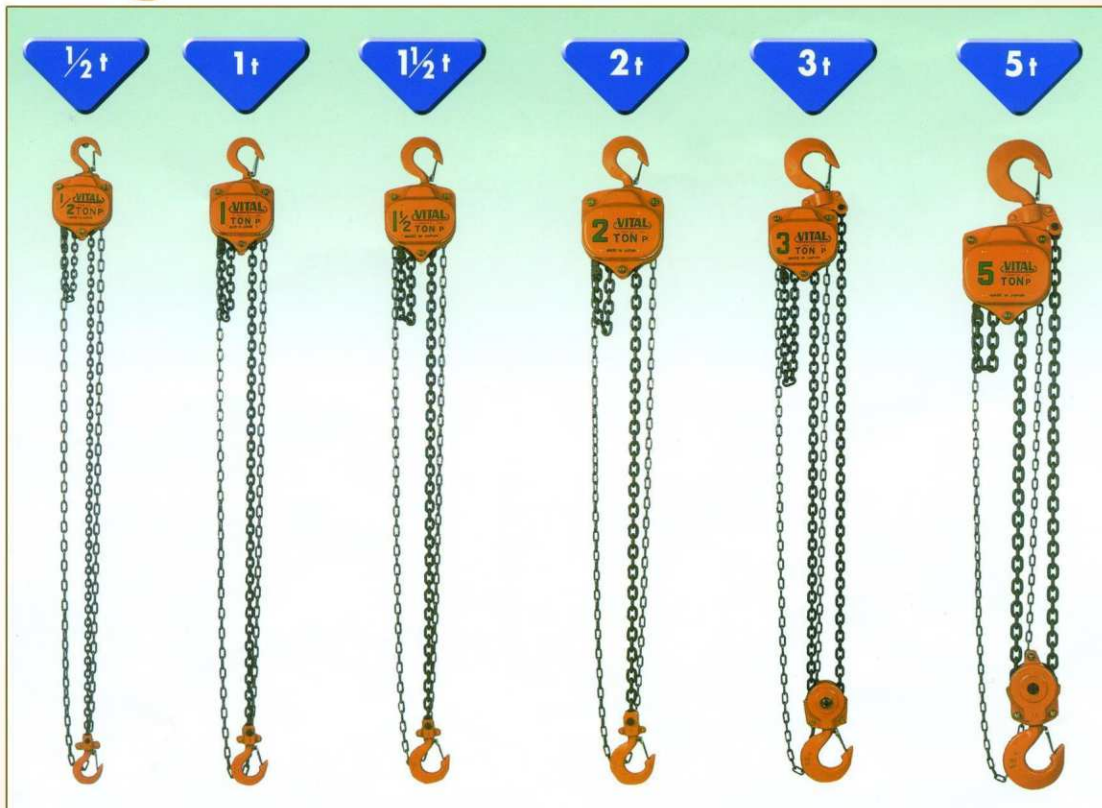

Specifications

جرثقیل‌های ویتال ژاپن در تناژهای مختلف (جهت جابجایی بار)

Load Chain : With special alloy load chain.

Capacity (t)	Model Number	Standard Lift (m)	Net Weight (kg)	Gross Weight (kg)	Pull to Lift Load		Head Room c (mm)	a (mm)	b (mm)	g (mm)	Test Load (t)
					(kgf)	(N)					
1/2	VP5-05	2.5	8.3	8.7	25	245	285	127	144	27	0.75
1	VP5-10	2.5	11.3	11.8	33	324	315	147	157	30	1.5
1 1/2	VP5-15	2.5	13.5	14.0	34	333	340	147	174	34	2.25
2	VP5-20	3.0	21.0	22.2	34	333	380	179	204	37	3.0
3	VP5-30	3.0	22.0	22.7	35	343	475	147	206	43	4.5
5	VP5-50	3.0	40.0	41.5	39	382	600	179	263	47	6.3

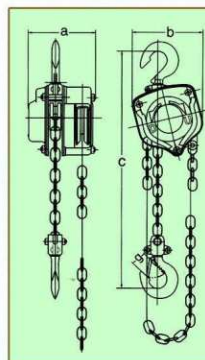

ریل (ترولی) جهت جرثقیل‌های دستی ویتال ژاپن

AG Geared Trolley

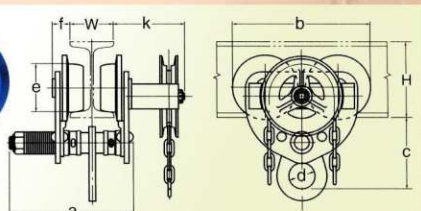

Geared Trolley

AG	Capacity (t)	75	125	150	180	250	294	206	231	120	45	80	27	117	1300	14.0	AG-10
	1	75	125	150	180	250	294	206	231	120	45	80	27	117	1300	14.0	AG-10
	2	100	150	180	250	400	294	241	271	155	60	100	33	119	1500	23.5	AG-20
	3	100	150	180	250	400	294	261	311	185	70	113	47	134	2000	33.5	AG-30
	5	125	175	250	450	450	294	294	351	220	80	125	53	134	2600	53.5	AG-50
	10	150	175	250	450	450	294	294	721	165	—	125	53	134	—	101.0	AG-90

بازرگانی رحیمی

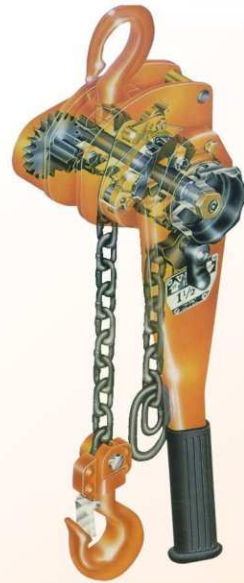

■ پولیف ویتال ژاپن در تناژ مختلف



Specifications

Model number	VR2-08	VR2-10	VR2-15	VR2-30	VR2-60	
Capacity (t)	3/4	1	1-1/2	3	6	
Standard lift (m)	1.5	1.5	1.5	1.5	1.5	
Net weight (kg)	6.9	7.1	9.7	16.3	26.7	
Minimum distance between hooks (mm)	295	310	335	405	550	
Pull on lever to lift full load	(kgf)	15	20	18	38	39
	(N)	147	196	177	373	382
Chain thickness (mm)	6.3	6.3	7.1	9.0	9.0	
Dimensions	a (mm)	148	148	163	191	191
	b (mm)	128	128	148	181	244
	c (mm)	295	310	335	405	550
	d (mm)	256	256	368	368	368
	e (mm)	27	30	34	43	47

· Hoists with the life in other lengths are also available.

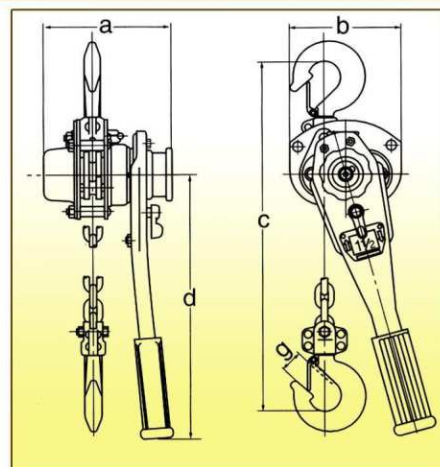

بازرگانی رحیمی

تيفور سوپرتيل ژاين درتناژ مختلف

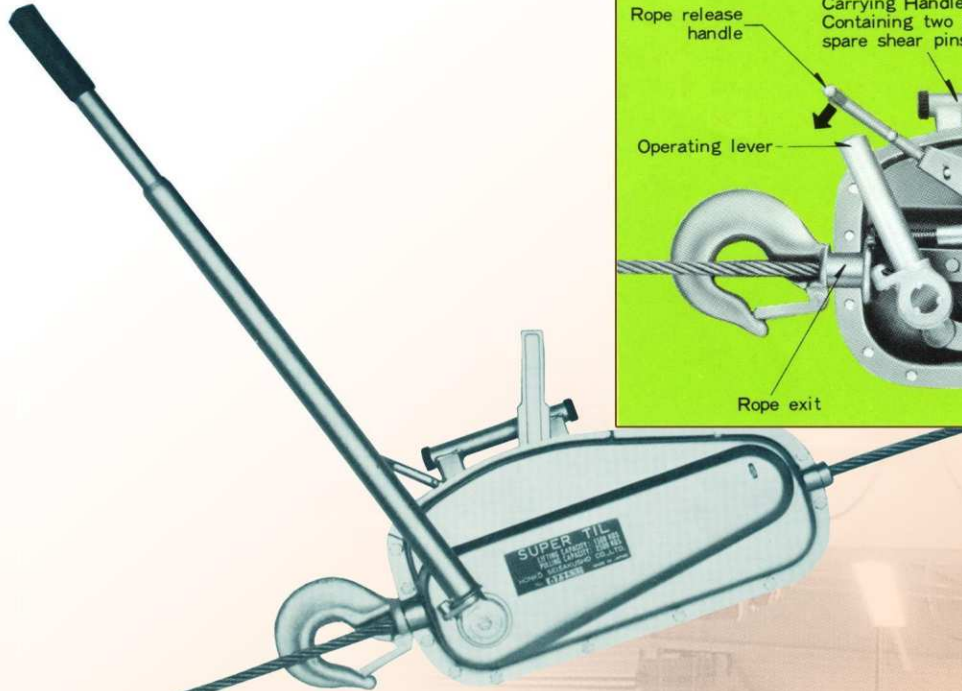
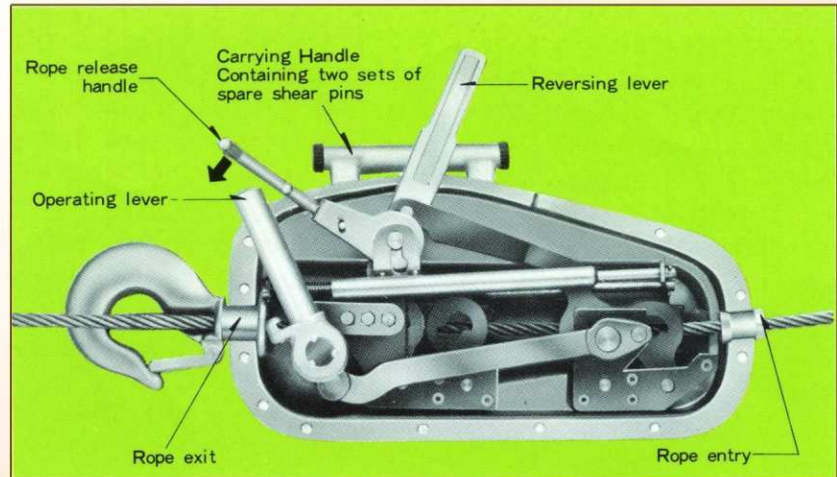

Specification

Model No.	S-7	S-15	S-35
Lifting capacity:	800 kg	1,600 kg	3,200 kg
Pulling capacity:	1,250 kg	2,500 kg	5,000 kg
Test to:	1,500 kg	3,000 kg	6,000 kg
Length of handle	790 mm	1,050 mm	1,210 mm
Steel wire rope	IWRC 9mm dia.	IWRC 12mm dia.	IWRC 16mm dia.
Net weight (without wire rope)	8 kg	22 kg	31.5 kg
External dimension	50×25×10cm	62×30×15cm	72×32×14cm
Material casing	SS41 (JIS)	SS41 (JIS)	AL casting
Transmission speed rate per minute	3meters	3meters	3meters
Breaking strength of wire rope	5,430 kg	9,680 kg	17,200 Kg
safety device	safety pins	safety pins	safety pins

بازرگانی رحیمی

جرثقیل برقی سامسونگ (SAMSUNG) کره

با خدمات پس از فروش

جرثقیل برقی سامسونگ ۴ کاره تکسرعت و دوسرعت مدل SCT

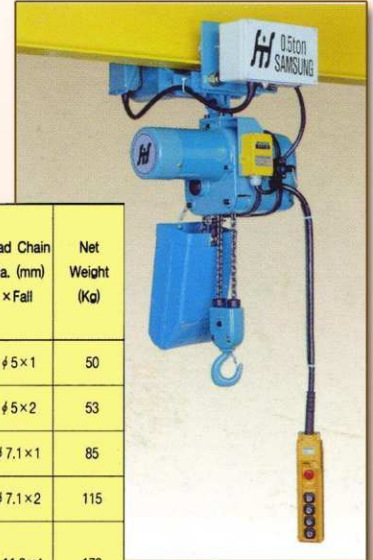

Type	Model	Capacity (Kg)	Rating (min)	Motor				Speed				Min. Radius For Curve (mm)	I-Beam Width (mm)	Load Chain Dia. (mm) × Fall	Net Weight (Kg)
				Hoisting 3 Phase (Kw)		Traversing 3 Phase (Kw)		Hoisting (m/min)		Traversing (m/min)					
				50 Hz	60 Hz	50 Hz	60 Hz	50 Hz	60 Hz	50 Hz	60 Hz				
Single Speed	SCT-S 025	250	30	0.42	0.5	0.17	0.2	7	8.4	16.7	20	1200	75-125	φ 5×1	50
	SCT-S 050	500						3.5	4.2					φ 5×2	53
	SCT-S 100	1000		1.25	1.5	0.33	0.4	5.8	7	1500	100-150	φ 7.1×1	85		
	SCT-S 200	2000						2.9	3.5			φ 7.1×2	115		
	SCT-S 280	2800		3.0	3.5	0.33	0.4	5	6	2000	125-175	φ 11.2×1	173		
	SCT-S 300	3000						15.8	19			φ 11.2×2	255		
	SCT-S 500	5000						2.5	3			13.3	16	φ 11.2×2	255
Dual Speed	SCT-D 100	1000	30/15	1.25/0.63	1.5/0.75	0.17	0.2	5.8/2.9	7/3.5	16.7	20	1200	75-125	φ 7.1×1	94
	SCT-D 200	2000						2.9/1.5	3.5/1.75					φ 7.1×2	113
	SCT-D 280	2800		3.0/1.5	3.5/1.75	0.33	0.4	5/2.5	6/3	1500	100-150	φ 11.2×1	188		
	SCT-D 300	3000						15.8	19			φ 11.2×2	270		
	SCT-D 500	5000						2.5/1.25	3/1.5			13.3	16	φ 11.2×2	270

جرثقیل برقی سامسونگ ۲ کاره مدل SC

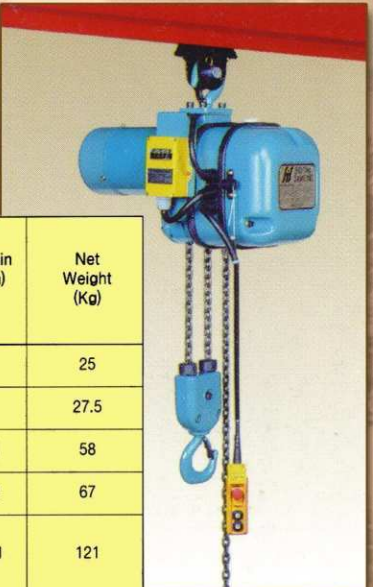

Type	Model	Capacity (Kg)	Rating (min)	Hoisting Motor 3 Phase (Kw)		Hoisting Speed (m/min)		Load Chain Dia. (mm) × Fall	Net Weight (Kg)
				50 Hz	60 Hz	50 Hz	60 Hz		
Single Speed	SC-S 025	250	30	0.42	0.5	7	8.4	φ 5×1	25
	SC-S 050	500				3.5	4.2	φ 5×2	27.5
	SC-S 100	1000		1.25	1.5	5.8	7	φ 7.1×1	58
	SC-S 200	2000				2.9	3.5	φ 7.1×2	67
	SC-S 280	2800		3.0	3.5	5	6	φ 11.2×1	121
	SC-S 300	3000				15.8	19	φ 11.2×2	159
	SC-S 500	5000				2.5	3	13.3	16
Dual Speed	SC-D 100	1000	30/15	1.25/0.63	1.5/0.75	5.8/2.9	7/3.5	φ 7.1×1	69
	SC-D 200	2000				2.9/1.5	3.5/1.75	φ 7.1×2	78
	SC-D 280	2800		3.0/1.5	3.5/1.75	5/2.5	6/3	φ 11.2×1	136
	SC-D 300	3000				15.8	19	φ 11.2×2	170
	SC-D 500	5000				2.5/1.25	3/1.5	13.3	16

بازرگانی رحیمی

جرثقیل برقی بالکان کار



بالابر برقی سبک



وینچ برقی

CWG-30375, 30565, 30750, 31500, 34000, 38500

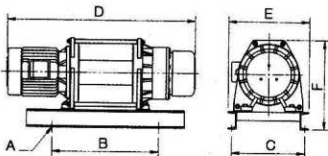
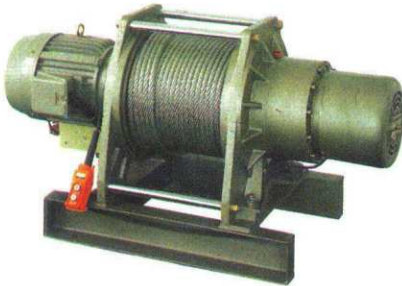

Model	Load rated Kg	Speed M/min	Motor HpxP	Power Source	Lifting Height M	Wire Rope ϕ mmxM	N.W Kg	Percentage Duty Cycle
30375	900	13-20.6 8.5-12.5	5x4 3X6	3 Phase 50Hz 220V 380V 400V 415V	58	10x60	220	25% ED (150 times/h maximum starting frequency)
30565	1100	14-25 8.2-16.7	7.5x4 5x6		97	12x100	290	
30750	2200	7-12.5 4.6-8.3	7.5x4 5x6		97	16x100	450	
31500	3500	6.3-8.8 4.6-6.6	7.5x6 5x8		144	18x150	860	
34000	5000	8.0-12 5.3-8	15x4 10x6		192	22.4x200	1500	
38500	10000	7~11	30x4		235	32x250	3000	

بازرگانی رحیمی

■ وینچ‌های جلوی ماشین



DV-2500i

Specifications

Line Pull	2,500lb(1,134kg)
Motor	0.67hp(500w)
Gear Train	3 stage planetary
Gear Ratio	170:1

DV-3500 i

Specifications

Line Pull	3,500lb(1,588kg)
Motor	1.2hp(900w)
Gear Train	3 stage planetary
Gear Ratio	170:1

DV-4500 i

Specifications

Line Pull	4,500lb(2,041kg)
Motor	1.6hp(1,200w)
Gear Train	3 stage planetary
Gear Ratio	170:1



DV-6000i

Specifications

Line Pull	6,000lb(2,722kg)
Motor	3.6hp(2,685w)
Gear Train	3 stage planetary
Gear Ratio	156:1
Wire Rope Length	80'(24.4m)Aircraft A7x19
Wire Rope Size	5/16 "(8 mm)

DV-

Specifications

Line Pull	9,000lb(4,082kg)
Motor	4.6hp(3,430w)
Gear Train	3 stage planetary
Gear Ratio	156:1
Wire Rope Length	125'(38.1m)Aircraft A7x19
Wire Rope Size	5/16"(8mm)

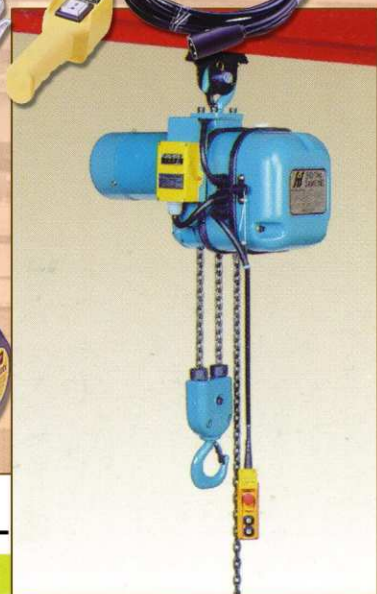

بازرگانی رحیمی



■ وینچ‌های دستی

HAND WINCH							
Model	LHW-600	LHW-800	LHW-1000	LHW-1200	LHW-1400	LHW-2000	LHW-2500
Cap.	600LBS	800LBS	1000LBS	1200LBS	1400LBS	2000LBS	2500LBS
Safe Working Load LBS	600	800	1000	1200	1400	2000	2500
Test Load(KN)	4	5.34	6.67	8	9.34	13.35	16.68
Gear Ratio	2.9:1	3.7:1	4.2:1	4.2:1	4.2:1	10.35:1/4.5:1	11.5:1/5:1
Unmber Of Speeds	1	1	1	1	1	1	2
Dimensions mm	A	232	232	232	232	310	310
	B	51	51	51	51	65	65
	C	180	180	180	180	180	251
	D	88	88	88	88	88	129.5
	E	165	165	184	184	184	243
	F	138	138	156	156	156	178
	G	25	25	25	25	25	25
	H	90	90	90	90	90	90
Net weight	kg	2.5	2.6	2.8	2.8	6.2	6.5
Volume	cm	17x13x21			21x21x27		

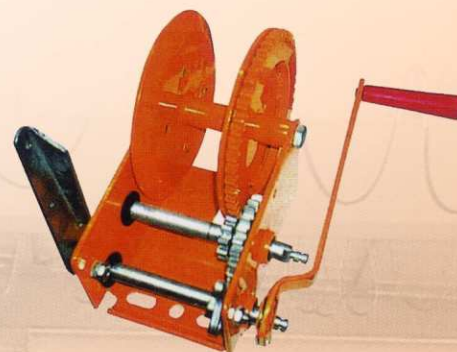
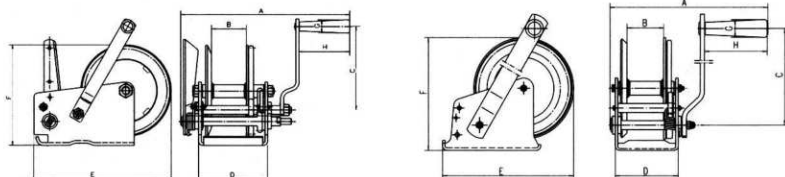

■ قیچی کابلر هیدرولیک

Wire Rope Cutter

Model	WRC30	WRC40	WRC50
Cutting Range	8-30mm	8-40mm	8-50mm
Blade Travel	30mm	63mm	63mm
Cutting Time	25s	40s	40s
Oil pump Diameter	12mm	12mm	12mm
Force Exerted On Handle	300N/30kg	400N/40kg	400N/40kg
Cutting Power	7.5T	20T	20T
Net weight	18.5kg	34kg	34kg
Carton Size	440x130x190mm	510x155x215mm	510x155x215mm

